

HAMC4242/HIMC4242
4nozzles • 2displays



HAMC4442/HIMC4442
4nozzles • 4displays



HAXC4443/HIXC4443
4nozzles • 6displays



Dimensions

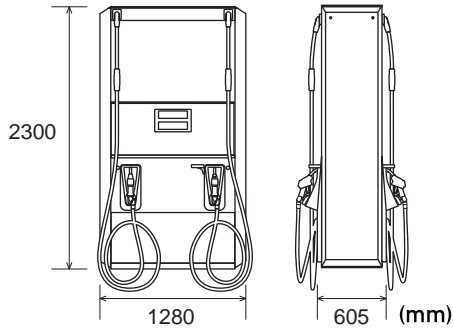

System Chart and Weight

C: Counter M: Meter P: Pump N: Nozzle

	HAMC4242/HIMC4242	HAMC4442/HIMC4442	HAXC4443/HIXC4443
Suction Pump Type	325kg	327kg	355kg
Submersible Turbine Pump (STP) Type	305kg	307kg	335kg

Specifications

	Suction Pump Type	Submersible Turbine Pump (STP) Type
Flow Rate	Normal:40L/min	Depends on the on-site STP capacity
	High:80L/min (40L/minute for concurrent refueling)	
Pump	Internal silent gear pump with air separator	
	Suction strainer, Flexible pipe	
	By-pass valve and Suction check valve	
Flexible Pipe	Flange type, 1-1/2" threaded	
Manual Drive Handle	Provided for manual operation during power failure	
Motor	Three-phase 380V 750W (Optional) Single-phase 220-240V 750W	
Meter	4-piston positive displacement flowmeter with electronic adjuster	
Accuracy	± 0.2%	
Indicator	LCD (Liquid Crystal Display)	
Character Color	Black characters on a white field with bright LED back light display	
Display	Amount - 7 digits H:50mm, Unit price - 5 digits H:23mm, Volume - 7 digits H:50mm	
Unit Price Setting	by infrared remote control unit or by keypad or by POS setting	
Electronic Totalizer	Fueling volume 10 digits, minimum:0.001L or 0.01L/money amount 10 digits	
Power Outage Indication	In case of power failure at control sector, refueling operation will automatically stop and indicator will continue display of amount already fueled for approximately 15 minutes.	
Electromagnetic Totalizer	(Optional) Fueling volume 7 digits, minimum 1 L	
Reset Device	Automatic reset	
Nozzle	Automatic nozzle, Spout outside diameter 21mm, 25mm	
Joint	Double Swivel Type (Optional) Rotary Type	
Hose	Black color hose, Oil resistance type, Inside diameter 16 mm	
Length	5m (Including the length of Nozzle and Safety breakaway coupling)	
Safety Breakaway Coupling	Provided	
Wiring	Cabtyre cable	
Emergency Stop Switch	Provided	
POS Interface	RS-485	
Line Fuel Filter	(Optional) 30μ paper filter	
Anti Static Touch Pad	(Optional)	
Sight Glass	(Optional)	
Receipt Printer	(Optional) Thermal type	
Advertisement Display	(Optional) 10.4" LCD type	

Distributor

SANKO PROGRESS MABIS CORPORATION

TOKYO : Nippon-Building 3F, 2-6-2 Otemachi, Chiyoda-ku, Tokyo 100-0004 Japan
Phone 81-3-6386-3504 Fax 81-3-6386-3522
E-mail bz@sanko-mabis.com URL http://www.sanko-mabis.com

Manufacturer

TOMINAGA MFG. CO.

88 Nishinokyo-Minamiryomachi, Nakagyo-ku, Kyoto 604-8493 Japan
Phone +81-75-801-8143 Fax +81-75-801-1373
E-mail info@kyoto-tmc.co.jp URL http://www.kyoto-tmc.co.jp

